

2. A. LOCATE "B" DIMENSION ON THE STOP. NOTE THAT THE "B" DIMENSION IS MEASURED FROM THE CENTERLINE OF THE HINGE AS SHOWN.
 B. FOR METAL FRAMES, USE A #7 DRILL AND A 1/4"-20 TAP IN 4 PLACES. FOR WOOD FRAMES, DRILL A 3/16" PILOT HOLES IN 4 PLACES.

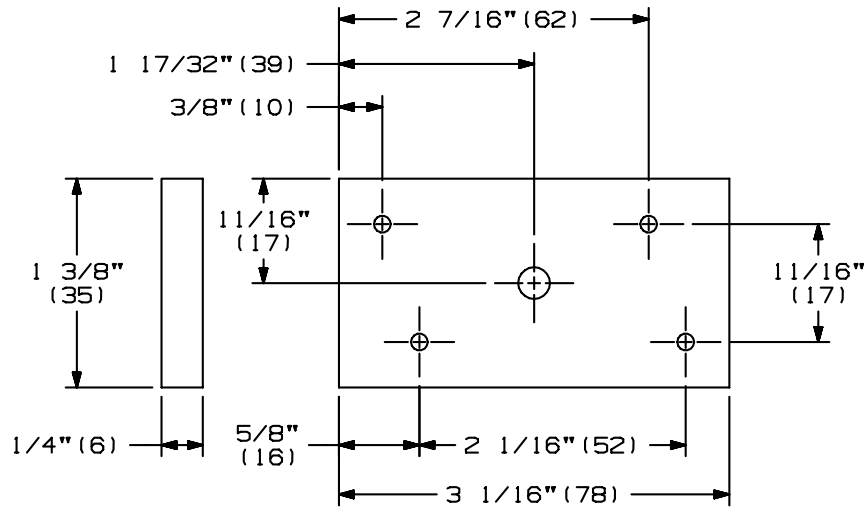

JAMB BRACKET

3. A. LOCATE "A" DIMENSION ON THE DOOR. NOTE THAT THE "A" DIMENSION IS MEASURED FROM THE CENTERLINE OF THE HINGE AS SHOWN.
 B. CHOOSE THE TYPE OF FASTENERS BEING USED TO MOUNT THE DOOR BRACKET TO THE DOOR.
 MOUNTING HOLES SHOULD BE PREPARED IN THE FIELD.
 1. MACHINE SCREWS TO A REINFORCED METAL DOOR, DRILL DOWN 7/8" (22) FROM THE STOP USING #7 DRILL AND 1/4"-20 TAP IN 3 PLACES.
 2. USING GROMMET NUTS ON THE OUTSIDE TWO MOUNTING HOLES, DRILL 7/8" (22) DOWN FROM STOP 9/32" (7) DIAMETER THROUGH DOOR IN 2 PLACES. ON THE CENTER HOLE FOR METAL DOORS, USE A #7 DRILL AND 1/4"-20 TAP OF FOR WOOD DOORS, DRILL A 3/16" PILOT HOLE.
 3. OPTIONAL, USING SEX BOLTS ON THE OUTSIDE TWO MOUNTING HOLES, DRILL 7/8" (22) DOWN FROM STOP 3/8" (10) DIAMETER THROUGH DOOR IN 2 PLACES. ON THE CENTER HOLE FOR METAL DOORS, USE A #7 DRILL AND 1/4"-20 TAP OR FOR WOOD DOORS, DRILL A 3/16" PILOT HOLES. NOT PROVIDED STANDARD, BUT AVAILABLE ON REQUEST.

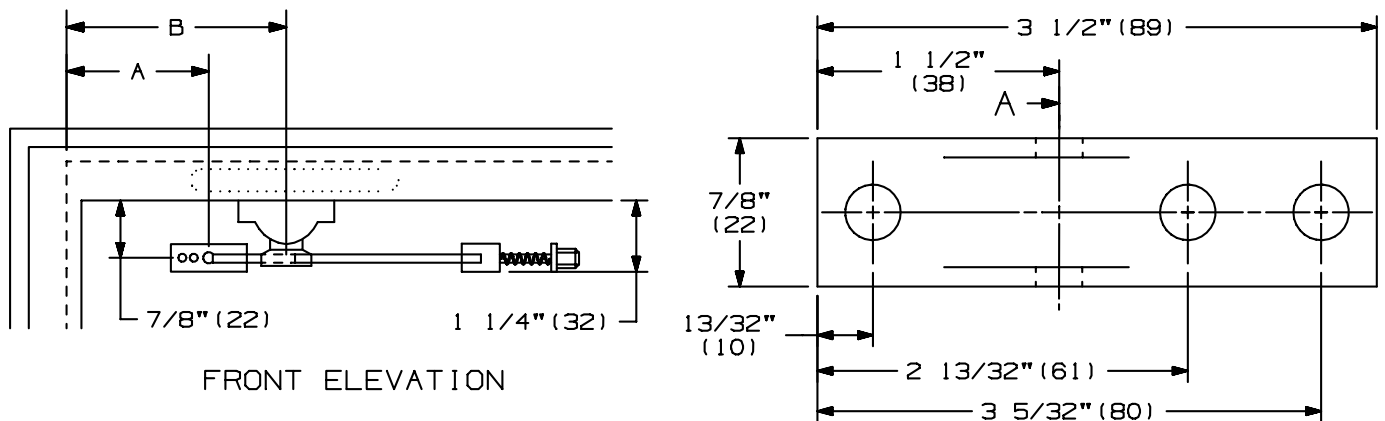

DOOR BRACKET

4. A. INSTALL JAMB BRACKET ON THE STOP.
 B. INSTALL THE DOOR BRACKET ON THE DOOR.

70 SERIES SURFACE OVERHEAD
 HOLDER INSTALLATION TEMPLATE



NOTE: DIMENSIONS IN () ARE MILLIMETERS.

TEMPLATE NUMBER: INST. 70 . PG2_1

DATE: 04-30-04

MOUNTING GROUPS 1 & 2
70 SERIES SURFACE OVERHEAD STOP & HOLDER
CAUTION: "A" & "B" DIMENSIONS ARE MEASURED FROM THE
CENTERLINE OF PIVOT, NOT EDGE OF DOOR
FOR DEAD STOP ADD 3/8" (10) TO THE "A" & "B" DIMENSIONS
HO-HOLD-OPEN FOR HOLDERS, OPENING FOR STOPS

DEGREE	85 HO		90 HO		95 HO		100 HO		105 HO		110 HO		BAR LENGTH		
	DIM.	DOOR OPENING	A	B	A	B	A	B	A	B	A	B			
702	IN.	23 1/16-27	5 3/8	10 1/16	5	9 5/8	4 11/16	9 1/4	4 3/8	8 15/16	4 1/8	8 5/8	3 5/8	8 3/8	14 15/16
	mm	585-686	137	256	127	244	119	235	111	227	105	219	98	213	379
703	IN.	27 1/16-33	6 3/4	14 3/4	6 1/2	14 1/8	6 1/4	13 1/2	6	13	5 3/4	12 9/16	5 9/16	12 1/16	19 1/16
	mm	687-838	171	375	165	359	159	343	152	330	146	319	141	306	484
704	IN.	33 1/16-39	9 1/4	17 1/4	8 3/4	16 5/8	8 1/4	16 1/8	7 3/4	15 11/16	7 1/4	15 3/8	6 3/4	15 1/8	22 7/16
	mm	839-991	235	438	222	422	210	410	197	398	184	391	171	384	570
705	IN.	39 1/16-45	12	19 9/16	11 15/16	18 1/4	11 7/8	17	11 13/16	15 13/16	11 5/8	14 15/16	11 1/4	14 3/8	25 13/16
	mm	992-1143	305	497	303	464	302	432	300	402	295	379	286	365	656
706	IN.	45 1/16-54	14 1/4	22 13/16	14 1/8	21 3/8	14	20	13 7/8	18 3/4	13 3/4	17 5/8	13 3/8	16 15/16	29 9/16
	mm	1144-1372	362	579	359	543	356	508	352	476	349	448	340	430	751
702	IN.	27 1/16-33	5 3/8	10 1/8	5 1/16	9 3/4	4 3/4	9 7/16	4 1/2	9 1/8	4 5/16	8 3/4	4 1/16	8 9/16	14 15/16
	mm	687-838	137	257	129	248	121	240	114	232	110	222	103	217	379
703	IN.	33 1/16-39	9	12 9/16	8 1/2	12 1/16	8 1/8	11 9/16	7 3/4	11 3/16	7 7/16	10 3/4	7 1/8	10 7/16	19 1/16
	mm	839-991	229	319	216	306	206	294	197	284	189	273	181	265	484
704	IN.	39 1/16-45	11 11/16	14 7/8	11 1/8	14 3/16	10 5/8	13 5/8	10	13 5/16	9 5/8	12 7/8	9 1/8	12 5/8	22 7/16
	mm	992-1143	297	378	283	360	270	346	254	338	244	327	232	321	570
705	IN.	45 1/16-51	14 1/16	17 1/2	13 1/2	16 5/8	12 7/8	16	12 1/4	15 1/2	11 3/4	15	11 1/4	14 5/8	25 13/16
	mm	1144-1295	357	445	343	422	327	406	311	394	298	381	286	371	656
706	IN.	51 1/16-57	16 3/4	20 3/8	15 15/16	19 1/2	15 3/16	18 13/16	14 9/16	18 1/8	14 1/16	17 7/16	13 9/16	16 15/16	29 9/16
	mm	1296-1448	425	518	405	495	386	478	370	460	357	443	344	430	751
MOUNTING GROUP #1						MOUNTING GROUP #2									

**70 SERIES SURFACE OVERHEAD
 HOLDER INSTALLATION TEMPLATE**



NOTE: DIMENSIONS IN () ARE MILLIMETERS.

TEMPLATE NUMBER: INST. 70 . PG3_1

DATE: 04-30-04